

HQS-5050-60LED-19.2W-RGBxx-24V series

Professional LED strip LED 24V, 19.2W/m

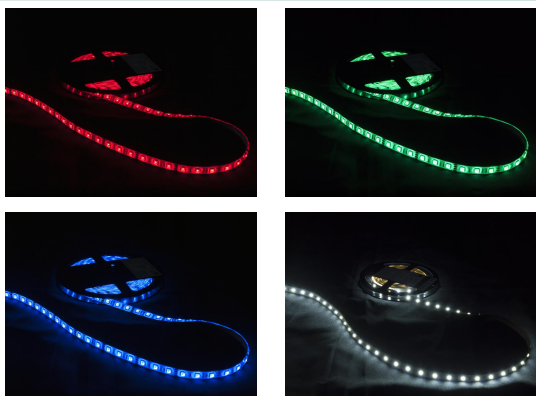

- Applications:
- Curve line lighting
 - Freeze lighting
 - Light bar applications

- Features:
- 2oz thickness FPC(Flexible Printed Circuit)
 - Can be cut every 5cm segment(3 LEDs in segment)
 - Each segment with couple pads for secondary operation
 - Enhanced 5050 LEDs
 - Easy installation with 3M adhesive tape

© MODEL ENCODING

HQS	-	5050	-	60 LED	-	19.2W	-	RGB	-	24V
Series	-	LED Chip	-	Led/m	-	Power per 1m	-	Led Color Temperatura	-	Voltage
								- RGBWW		Warm white
								- RGBNW		Neutral white
								- RGBW		White

© ELECTRICAL SPECIFICATION

MODEL	HQS-5050-60LED-19.2W-RGBxx-24V		
Chip	5050		
Supply voltage	24V ± 0.5VDC		
Current and Power per 1m	800mA; 19.2W		
Current and Power per reel (5m)	4A; 96W		
CCT (Correlated Color Temperature) / Wavelength	R : 620nm ÷ 630nm	G : 510nm ÷ 520nm	B : 460nm ÷ 470nm
Stream of light	32.3 lm ÷ 32.8 lm / W	26.5 lm ÷ 27.0 lm / W	24.0 lm ÷ 24.5lm / W
Maximum length for one sided supply	5m		
IP protection degree	IP33		
Working and storage temperature	-25°C ÷ +50°C; -25°C ÷ +60°C		
Cut Section	100mm		
Connection wire	5x AWG20(0.52mm ²) stranded wire, length = 140mm; V+: red; R: red; G: green; B: blue W: white		
Dimensions (L * W * H)	5000 * 12 * 1.5mm		
Packing	5m/roll(bag); 40pcs/ctn; ctn dimensions: 45x25x25.6cm		

MODEL	HQS-5050-60LED-14.4W-RGBW-24V	HQS-5050-60LED-14.4W-RGBNW-24V	HQS-5050-60LED-14.4W-RGBWW-24V
Rated color temperature of lighting	7 000K	4 000K	3 000K
The range of color temperatures of illumination	6 000K ÷ 8 000K	4 000K ÷ 5 000K	2 700K ÷ 4 000K
Beam Angle	120°		
Luminous Flux per meter and per watt	688lm ÷ 850lm / m; 48lm ÷ 59lm / W		

HQS-5050-60LED-19.2W-RGBxx-24V series

Professional LED strip LED 24V, 19.2W/m



© MECHANICAL SPECIFICATION

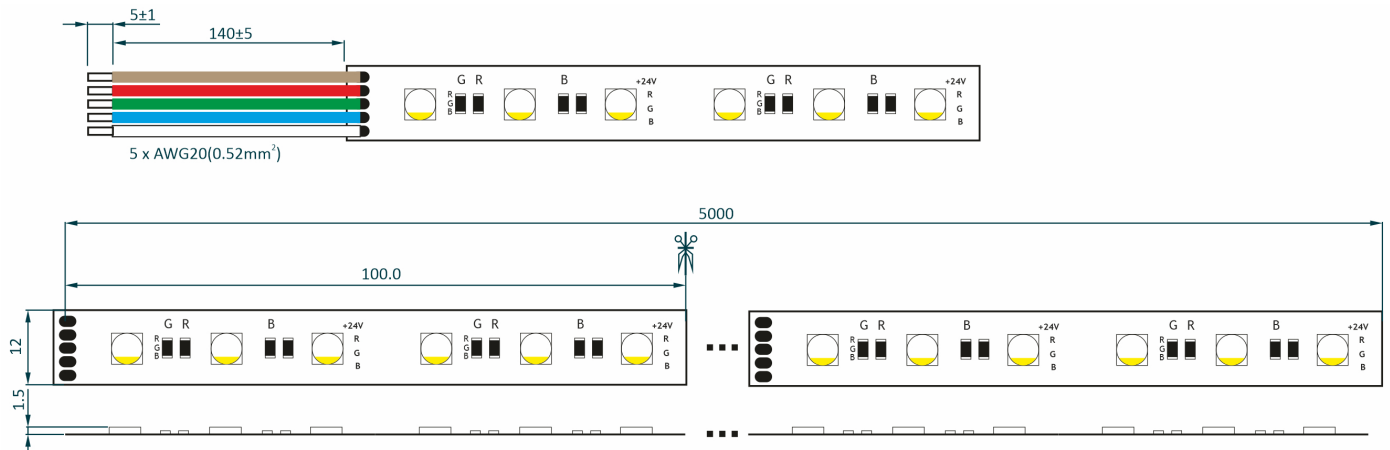

© SUPPLY

© Strip length < 5m

